

ECLIPSE TURBO BLOWERS SERIES "SMJ"

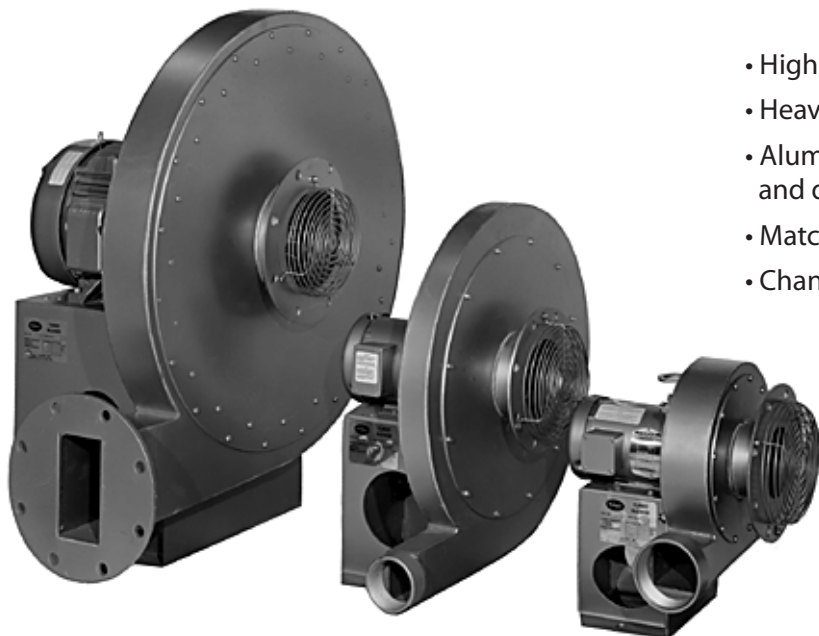

- High efficiency
- Heavy gauge steel base and housing
- Aluminum impellers balanced statically and dynamically
- Matching air filters available
- Changeable outlet positions

Eclipse "SMJ" Blowers are centrifugal blowers that provide low pressure air for industrial combustion systems. They are also used for cooling, conveying, drying, liquid agitation, smoke abatement, vacuum cleaning, fume and dust exhausting, and other applications where air temperatures are under 220°F (104°C).

All "SMJ" Blowers are constructed of continuous welded, heavy gauge steel. The impellers are made of lightweight, high strength, riveted aluminum. Outlets on 3" and 4" models are threaded, while all others are flanged for a standard 125# ANSI companion flange. Discharge ports are sized to keep pressure losses within reasonable limits.

Blower inlet flanges are equipped with a grill that complies with OSHA regulations. If desired, the grill may be removed and the inlet bolted to a standard ANSI companion flange. Eclipse-supplied motors are standard shaft and starting torque, ball bearing, 3600 rpm units. On any blower requiring 3/4 HP or more, Eclipse recommends that polyphase motors be used.

There are four possible outlet positions. Any existing position is easily changed by removing the housing from the blower base and remounting it in the desired position. Posi-

tions 1 through 3 can be specified for any blower. Position 4, however, requires factory approval before ordering. Position 1 is the standard assembly (bottom, horizontal) unless otherwise specified.

"SMJ" Blowers can be supplied with counterclock-wise (CCW) or clockwise (CW) rotation as viewed from the motor side. CCW rotation is furnished standard unless otherwise specified.

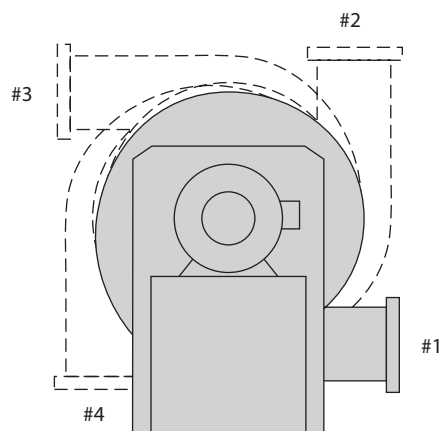

Outlet Positions

Model Variations

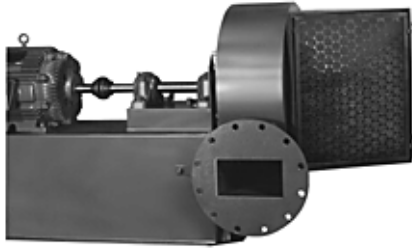

Type "D"
A.M.C.A. Arrangement #8

Type "D" construction features a separate impeller shaft connected to the motor shaft by a flexible coupling. It is often used where immediate interchangeability of motors is required (photo shows inlet filter installed).



Type "P"
A.M.C.A. Arrangement #1

Type "P" construction permits the blower to be driven by a gasoline engine, line shaft or other separate power source.

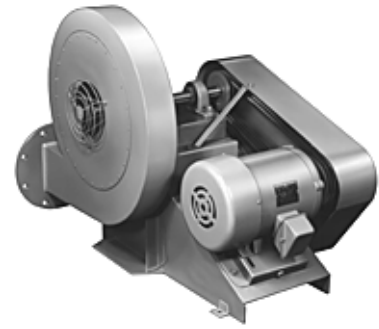

Type "V"
A.M.C.A. Arrangement #9

Type "V" construction is normally used when 60 cycle AC current is not available and motor speeds result in less than standard rpm. The V-belt drives the impeller at standard rpm regardless of motor speed.

Air Inlet Filters

Filters must be ordered separately.

Single
Washable Element
(Double Also Available)
Bulletin 615



Non-washable
Cylindrical Element
Bulletin 616



Round
Replaceable Element
Bulletin 614



Pressure Switches



Model AA-A2-6
Bulletin I-354

Eclipse-Dungs Air Pressure Switch

Model A2 is available in a wide selection of setpoint pressure ranges for a maximum pressure of 7 PSI (498 mbar). This pressure switch is CSA certified, FM approved and UL listed. Its calibrated blue knob provides easy and accurate adjustment. A 1/4" N.P.T. high pressure air inlet connection is located on the switch bottom.

Round Filters

Catalog Number	As-sembly Number	Blower Inlet Size	Max. Capacity	
			SCFH	m3/hr.
25FAJ-S	200758	4"	25,000	707
25FAJ-M	200757	6" & 8"	25,000	707
50FAJ	200756	6" & 8"	50,000	1,413
150FAJ-S	200754	6" & 8"	150,000	4,248
150FAJ-M	200755	10" & 12"	150,000	4,248
250FAJ-L	200753	10" & 12"	250,000	7,065

The discharge pressure of the blower will be reduced by approximately .15" w.c. (.37 mbar) with the filter assembly installed.

Capacities - 3600 rpm Motor

Blower Catalog No.	Motor HP	Service Factor	Inlet Size	Nominal Rating			
				"w.c.	SCFH	mbar	m3/hr.
SMJ 4610	1/3	1.35	6	7.0	6,900 *	17.4	195 *
SMJ 4610	1/2	1.25	6	7.0	15,000 *	17.4	425 *
SMJ 6812	1-1/2	1.15	8	9.5	40,300 *	23.7	1,141 *
SMJ 3412	1/3	1.35	4	10.0	4,800 *	24.9	136 *
SMJ 4412	1/2	1.25	4	10.0	8,600 *	24.9	243 *
SMJ 4412	3/4	1.25	4	10.0	14,000 *	24.9	396 *
SMJ 6812	1	1.25	8	10.0	32,800	24.9	929
SMJ 6812	2	1.15	8	10.0	45,000 *	24.9	1,274 *
SMJ 8815	5	1.15	8	10.4	92,500	25.9	2,620
SMJ 8814	3	1.15	8	11.0	69,000	27.4	1,954
SMJ 8813	3	1.15	8	11.5	72,000	28.6	2,039
SMJ 6614	2	1.15	6	11.6	44,600	28.9	1,263
SMJ 6614	1-1/2	1.15	6	13.0	37,000	31.1	1,048
SMJ 3414	3/4	1.25	4	14.0	10,000 *	34.9	283 *
SMJ 4614	1	1.25	6	14.0	21,200	34.9	600
SMJ 101016	7-1/2	1.15	10	14.1	140,400	35.1	3,976
SMJ 3414	1/2	1.25	4	14.7	7,530	36.6	213
SMJ 6615	2	1.15	6	15.0	32,000	37.4	906
SMJ 4615	1	1.25	6	15.5	23,000	38.6	651
SMJ 4616	1-1/2	1.15	6	15.5	27,000	38.6	765
SMJ 121217	15	1.15	12	15.6	223,000	38.9	6,315
SMJ 4615	3/4	1.25	6	15.8	13,600	39.4	385
SMJ 101016	10	1.15	10	16.0	163,000	39.9	4,616
SMJ 8816	5	1.15	8	17.0	70,000 *	42.3	1,982 *
SMJ 101016	7-1/2	1.15	10	17.0	86,000 *	42.3	2,436 *
SMJ 8815	3	1.15	8	17.1	52,000	42.6	1,473
SMJ 121217	10	1.15	12	19.1	150,000	47.6	4,248
SMJ 6617	2	1.15	6	19.6	25,700	48.8	728
SMJ 6617	3	1.15	6	19.9	38,000	49.6	1,076
SMJ 4617	1-1/2	1.15	6	20.0	15,000 *	49.8	425 *
SMJ 8817	7-1/2	1.15	8	20.0	85,000 *	49.8	2,407 *
SMJ 101018	15	1.15	10	20.0	165,000 *	49.8	4,673 *
SMJ 4616	1	1.25	6	20.2	16,500	50.3	467
SMJ 8817	5	1.15	8	21.2	67,500	52.8	1,912
SMJ 121220	20	1.15	12	26.0	202,000	64.8	5,721
SMJ 3619	1-1/2	1.15	6	27.0	15,300	67.3	433
SMJ 3619	2	1.15	6	27.0	20,000	67.3	566
SMJ 4619	2	1.15	6	27.0	20,000	67.3	566
SMJ 6619	5	1.15	6	27.4	49,100	68.3	1,391
SMJ 6619	3	1.15	6	27.8	27,300	69.2	773
SMJ 8819	7-1/2	1.15	8	27.8	70,500	69.2	1,997
SMJ 121219	15	1.15	12	27.8	150,000	69.2	4,248
SMJ 101019	10	1.15	10	28.4	87,500	70.7	2,478
SMJ 121221	25	1.15	12	30.0	209,000 *	74.7	5,919 *
SMJ 6621	3	1.15	6	31.0	18,300	77.2	518
SMJ 6621	5	1.15	6	31.5	36,800	78.5	1,042
SMJ 4621	2	1.15	6	32.1	9,100	80.0	258
SMJ 8821	7-1/2	1.15	8	32.3	48,000	80.5	1,359
SMJ 8821	10	1.15	8	32.6	74,500	81.2	2,110
SMJ 101021	20	1.15	10	34.0	133,000 *	84.7	3,767 *
SMJ 101021	15	1.15	10	34.2	121,500	85.2	3,441
SMJ 121222	25	1.15	12	35.4	213,000	88.2	6,032
SMJ 4623	3	1.15	6	37.2	11,600	92.7	328
SMJ 101023	25	1.15	10	38.6	178,000	96.1	5,041
SMJ 8823	15	1.15	8	38.9	102,000	96.9	2,889
SMJ 6623	7-1/2	1.15	6	39.0	42,500	97.1	1,204
SMJ 101023	20	1.15	10	39.8	136,000	99.1	3,852
SMJ 8823	10	1.15	8	40.5	60,000	100.9	4,531
SMJ 4623	5	1.15	6	41.1	29,500	102.4	835
SMJ 8828	10	1.15	8	54.8	40,000	136.5	1,133
SMJ 4628	5	1.15	6	55.0	14,500	137.0	411
SMJ 4628	7-1/2	1.15	6	55.8	28,100	139.0	796
SMJ 8828	15	1.15	8	58.5	63,000	145.7	1,784
SMJ 8828	25	1.15	8	59.0	95,000 *	147.0	2,690 *
SMJ 8828	20	1.15	8	60.0	91,000	149.5	2,577

Pressures are corrected for an air inlet temperature of 70°F (21°C) and a barometric pressure of 29.92" Hg (1.01 bar).

*Greater flows available at reduced pressure. See blower curves for details (Data 610).

Dimensions & Specifications –English Units

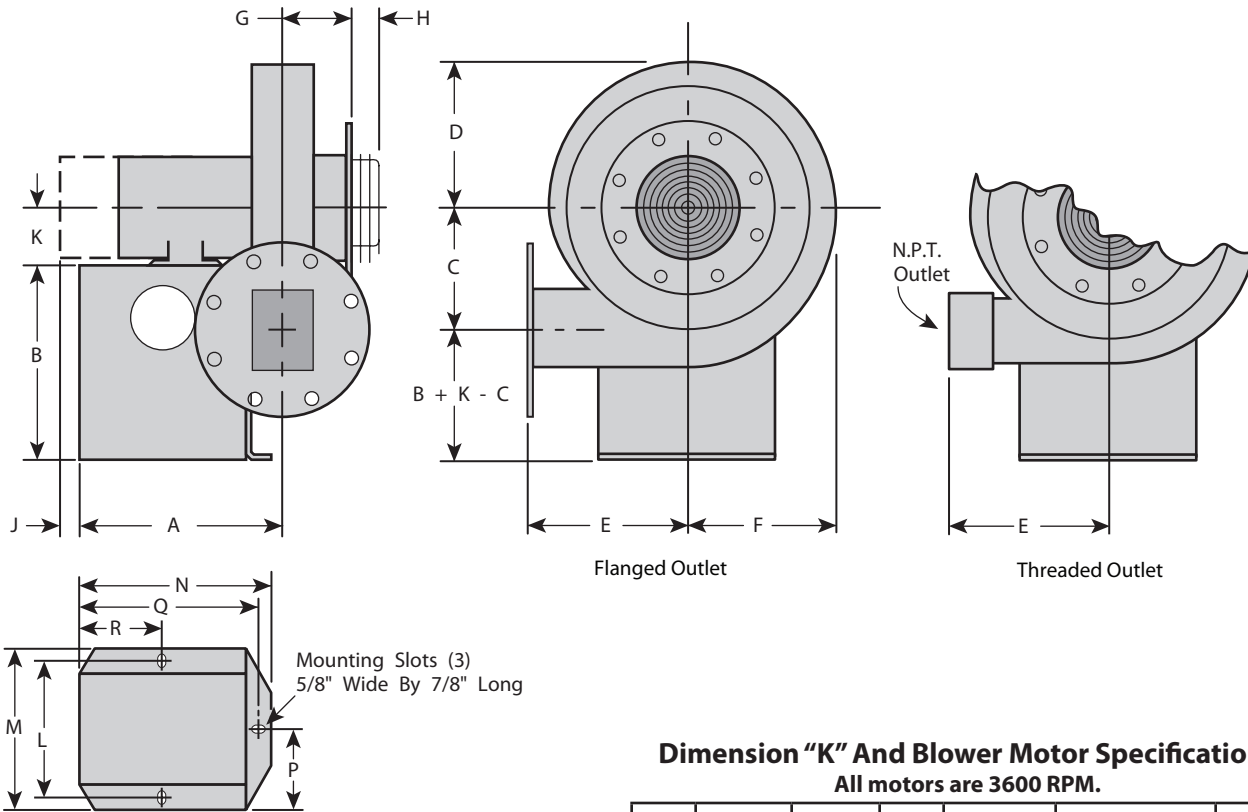

Dimension "K" And Blower Motor Specifications All motors are 3600 RPM.

Base*	Dimensions, In Inches						Bolt Dia.
	L	M	N	P	Q	R	
1	7-3/4	9-3/4	10	4-7/8	9	3-7/8	1/2
2	9-1/4	11-1/4	11	5-5/8	10	4-3/8	1/2
3	10	12	11-1/2	6	11	4-5/8	1/2
4	11	13	12	6-1/2	11	4-7/8	1/2
5	12	14	15-1/2	7	14-1/2	6-5/8	1/2
6	13-3/4	15-3/4	17-1/2	7-7/8	16-1/2	7-5/8	1/2
7	17	19	19-1/2	9-1/2	18-1/2	8-5/8	1/2

* See the main dimension table to find the base used on each blower.

HP	Encl.	Frame Size	S.F.	Dim. "K" (Inches)	V./Ph./Hz.	Part
1/3	Open	48	1.35	3	115/230/1/60	11175
1/3	TEFC	48	1.35	3	115/230/1/60	10755
1/3	Open	48	1.35	3	230/460/3/60	17745
1/3	TEFC	48	1.35	3	230/460/3/60	10448
1/2	Open	48	1.25	3	115/230/1/60	11180
1/2	TEFC	48	1.25	3	115/230/1/60	18776
1/2	Open	48	1.25	3	230/460/3/60	11178
1/2	TEFC	48	1.25	3	230/460/3/60	10449
1/2	Open	56	1.25	3-1/2	230/460/3/60	10047
1/2	TEFC	56	1.25	3-1/2	230/460/3/60	10032
3/4	Open	56	1.25	3-1/2	115/230/1/60	11182
3/4	TEFC	56	1.25	3-1/2	115/230/1/60	18777
3/4	Open	56	1.25	3-1/2	230/460/3/60	11183
3/4	TEFC	56	1.35	3-1/2	230/460/3/60	17723
1	Open	56	1.25	3-1/2	115/230/1/60	11187
1	TEFC	56	1.25	3-1/2	230/460/3/60	18881
1	Open	56	1.25	3-1/2	230/460/3/60	11189
1-1/2	Open	56	1.15	3-1/2	115/230/1/60	16742
1-1/2	Open	143T	1.15	3-1/2	230/460/3/60	11192
1-1/2	TEFC	143T	1.15	3-1/2	230/460/3/60	11197
2	Open	145T	1.15	3-1/2	230/460/3/60	11203
2	TEFC	145T	1.15	3-1/2	230/460/3/60	11199
3	Open	145T	1.15	3-1/2	230/460/3/60	11207
3	TEFC	182T	1.15	4-1/2	230/460/3/60	11209
5	Open	182T	1.15	4-1/2	230/460/3/60	11213
5	TEFC	184T	1.15	4-1/2	230/460/3/60	11210
7-1/2	Open	184T	1.15	4-1/2	230/460/3/60	11214
7-1/2	TEFC	213T	1.15	5-1/4	230/460/3/60	11215
10	Open	213T	1.15	5-1/4	230/460/3/60	11216
10	TEFC	215T	1.15	5-1/4	230/460/3/60	11217
15	Open	215T	1.15	5-1/4	230/460/3/60	11221
15	TEFC	254T	1.15	6-1/4	230/460/3/60	11220
20	Open	254T	1.15	6-1/4	230/460/3/60	11224
20	TEFC	256T	1.15	6-1/4	230/460/3/60	19894
25	Open	256T	1.15	6-1/4	230/460/3/60	14072
25	TEFC	284T	1.15	7	230/460/3/60	16764

Flange Dimensions

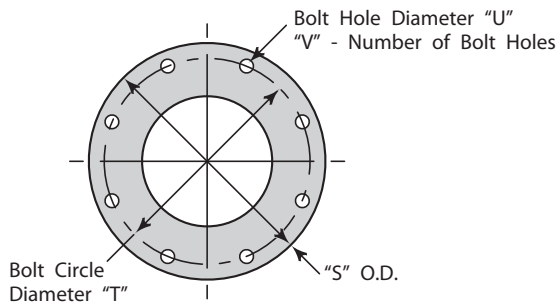

Nominal Pipe Size	Dimensions, In Inches				Bolt Dia.
	S	T	U	V	
3	7-1/2	6	3/4	4	5/8
4	9	7-1/2	3/4	8	5/8
6	11	9-1/2	7/8	8	3/4
8	13-1/2	11-3/4	7/8	8	3/4
10	16	14-1/4	1	12	7/8
12	19	17	1	12	7/8

Flange bolt patterns match ANSI 125# standards.

Dimensions & Specifications –English Units (continued)

Blower Catalog No.	Motor HP ¹	Inlet	Outlet	Dimensions In Inches									Base ¹
				A	B	C	D	E	F	G	H	J	
SMJ 3412 ³	1/3	4	3	9-3/16	9-1/2	7-1/2	8-3/8	10-1/8	8-11/16	4	1-7/8	—	1
SMJ 3414 ³	1/2 & 3/4	4	3	10	9-1/2	8-5/16	9-3/16	10-9/16	9-9/16	3-13/16	1-7/8	—	2
SMJ 3414	1/2 & 3/4	4	3	10	9-1/2	8-5/16	9-3/16	10-9/16	9-9/16	3-13/16	1-7/8	—	2
SMJ 3619 ³	1-1/2 & 2	6	3	11-3/16	12-1/2	11-3/4	13	15-5/8	13-5/16	4	1-7/8	—	4
SMJ 4412 ³	1/2	4	4	9-5/8	9-1/2	6-1/2	7-7/8	10-13/16	8-1/16	4-7/16	1-7/8	—	1
SMJ 4412 ³	3/4	4	4	10-5/8	9-1/2	6-1/2	7-7/8	10-13/16	8-1/16	4-7/16	1-7/8	—	1
SMJ 4610 ³	1/3 & 1/2	6	4	9-13/16	9-1/2	5-13/16	6-11/16	9-13/16	6-7/8	4-5/8	1-7/8	1-1/4	1
SMJ 4614 ³	1	6	4	11-1/2	12-1/2	8-11/16	10	13-13/16	10-3/16	4-5/16	1-7/8	—	4
SMJ 4615 ³	3/4 & 1	6	4	11-1/2	12-1/2	8-11/16	10	13-13/16	10-3/16	4-5/16	1-7/8	—	4
SMJ 4616 ³	1 & 1-1/2	6	4	11-3/8	12-1/2	9-1/2	11-1/8	14-13/16	11-5/16	4-3/16	1-7/8	—	4
SMJ 4617 ³	1-1/2	6	4	11-3/8	12-1/2	9-1/2	11-1/8	14-13/16	11-5/16	4-3/16	1-7/8	—	4
SMJ 4619 ³	2	6	4	11-1/4	12-1/2	11-3/4	13	15-13/16	13-5/16	4	1-7/8	—	4
SMJ 4621	2	6	4	15-3/16	15-1/2	12-3/4	14-3/8	16-7/8	14-1/2	4-1/2	1-7/8	—	5
SMJ 4623	3	6	4	15-5/16	15-1/2	13-9/16	14-11/16	15-3/8	15-3/8	4-5/8	1-7/8	—	5
SMJ 4623	5	6	4	15-5/16	15-1/2	14	15-1/16	15-3/8	15-3/8	4-5/8	1-7/8	—	5
SMJ 4628	5 & 7-1/2	6	4	17-1/16	19	16-7/8	18-3/16	18-3/8	18-1/2	4-9/16	1-7/8	—	6
SMJ 6614	1-1/2 & 2	6	6	12-7/16	12-1/2	8-1/4	9-13/16	12-3/8	10	5-1/4	1-7/8	—	4
SMJ 6615	2	6	6	12-7/16	12-1/2	8-1/4	9-13/16	12-3/8	10	5-1/4	1-7/8	—	4
SMJ 6617	2 & 3D	6	6	11-7/8	12-1/2	9-3/8	11-1/8	13-3/8	11-1/4	4-3/4	1-7/8	—	4
SMJ 6617	3E	6	6	11-7/8	12-1/2	9-3/8	11-1/8	13-3/8	11-1/4	4-3/4	1-7/8	1/2	5
SMJ 6619	3	6	6	15-3/16	15-1/2	11-3/4	13	14-3/8	13-5/16	4-1/2	1-7/8	—	5
SMJ 6619	5	6	6	15-3/16	15-1/2	11-3/4	13	14-3/8	13-5/16	5-3/4	1-7/8	—	5
SMJ 6621	3 & 5	6	6	14-3/4	15-1/2	12	14-1/16	14-3/8	14-9/16	4-1/16	1-7/8	—	5
SMJ 6623	7-1/2	6	6	15-15/16	15-1/2	12-9/16	15	17-3/8	15-1/4	5-3/16	1-7/8	—	5
SMJ 6812	1,1-1/2,2D	8	6	12	12-1/2	7-5/16	8-7/16	10-3/8	8-13/16	5-1/4	1-7/8	—	3
SMJ 6812	2E	8	6	12	12-1/2	7-5/16	8-7/16	10-3/8	8-13/16	5-1/4	1-7/8	1/2	3
SMJ 8813	3D	8	8	14-1/2	12-1/2	8-7/8	10	12-3/8	10-9/16	7-5/16	1-7/8	—	4
SMJ 8813	3E	8	8	14-1/2	12-1/2	8-7/8	10	12-3/8	10-9/16	7-5/16	1-7/8	9/16	4
SMJ 8814	3	8	8	16	15-1/2	9-11/16	11-1/4	12-3/8	12-1/16	5-1/4	1-7/8	—	5
SMJ 8815	3 & 5	8	8	16	15-1/2	9-11/16	11-1/4	12-3/8	12-1/16	5-1/4	1-7/8	—	5
SMJ 8816	5	8	8	16	15-1/2	9-11/16	11-1/4	12-3/8	12-1/16	5-1/4	1-7/8	—	5
SMJ 8817	5 & 7-1/2	8	8	16-7/16	15-1/2	9-7/8	11	13-7/8	11-7/8	5-3/4	1-7/8	—	5
SMJ 8819	7-1/2 & 10	8	8	16-1/8	15-1/2	13	14-5/16	15-3/8	15-3/16	5-7/16	1-7/8	—	5
SMJ 8821	7-1/2 & 10	8	8	18-1/2	19	14	15-1/2	15-3/8	16-7/16	5-3/4	1-7/8	—	6
SMJ 8823	10 & 15	8	8	20-1/8	19	14-9/16	16	16-3/8	16-7/8	5-1/2	1-7/8	—	7
SMJ 8828	10 & 15D	8	8	19-1/2	19	15-1/4	18-1/8	22-3/8	18-3/8	4-7/8	1-7/8	—	7
SMJ 8828	15E,20,25D	8	8	19-1/2	19	15-1/4	18-1/8	22-3/8	18-3/8	4-7/8	1-7/8	1-9/16	7
SMJ 8828	25E	8	8	19-1/2	19	15-1/4	18-1/8	22-3/8	18-3/8	4-7/8	1-7/8	3-1/8	7
SMJ 101016	7-1/2	10	10	18-11/16	15-1/2	10-13/16	12	14-3/8	12-3/4	8	2-3/8	—	5
SMJ 101016	10	10	10	20-11/16	19	10-13/16	12	14-3/8	12-3/4	8	2-3/8	—	6
SMJ 101018	15D	10	10	20-1/4	19	12-1/4	13-1/4	14-3/8	14-9/16	7-9/16	2-3/8	—	6
SMJ 101018	15E	10	10	20-1/4	19	12-1/4	13-1/4	14-3/8	14-9/16	7-9/16	2-3/8	1-7/8	6
SMJ 101019	10	10	10	19-3/4	19	13	14-3/8	15-3/8	15-1/4	7-1/16	2-3/8	—	6
SMJ 101021	15 & 20	10	10	21-7/16	19	14	15-1/2	15-3/8	16-7/16	6-3/4	2-3/8	—	7
SMJ 101023	20	10	10	20-13/16	19	14-3/16	16	18-3/8	17	6-3/16	2-3/8	—	7
SMJ 101023	25D	10	10	20-13/16	19	14-3/16	16	18-3/8	17	6-3/16	2-3/8	1-5/8	7
SMJ 101023	25E	10	10	20-13/16	19	14-3/16	16	18-3/8	17	6-3/16	2-3/8	3-1/8	7
SMJ 121217	10 & 15D	12	12	20-11/16	19	10-13/16	12	14-3/8	12-3/4	8	2-3/8	—	6
SMJ 121217	15E	12	12	20-11/16	19	10-13/16	12	14-3/8	12-3/4	8	2-3/8	1-3/4	6
SMJ 121219	15D	12	12	23	19	13	14-1/2	15-3/8	15-1/4	8-1/4	2-3/8	—	7
SMJ 121219	15E	12	12	23	19	13	14-1/2	15-3/8	15-1/4	8-1/4	2-3/8	—	7
SMJ 121220	20	12	12	23	19	13	14-1/2	15-3/8	15-1/4	8-1/4	2-3/8	—	7
SMJ 121221	25D	12	12	22-1/16	19	14	15-9/16	15-3/8	16-7/16	7-3/8	2-3/8	1-5/8	7
SMJ 121221	25E	12	12	22-1/16	19	14	15-9/16	15-3/8	16-6/16	7-3/8	2-3/8	3-1/8	7
SMJ 121222	25D	12	12	22-1/16	19	14	15-9/16	15-3/8	16-7/16	7-3/8	2-3/8	1-5/8	7
SMJ 121222	25E	12	12	22-1/16	19	14	15-9/16	15-3/8	16-7/16	7-3/8	2-3/8	3-1/8	7

¹D=open motor; E=enclosed motor. Horsepowers with no letter suffix are either open or enclosed.

²Refer to the base chart on page 4 for base mounting dimensions.

³Signifies an N.P.T. threaded outlet. All other blowers have flanged outlets with standard ANSI 125# bolt patterns. All inlets are flanged. Companion flanges are not standard, but are available at a nominal cost.

To Order: Specify blower catalog number, CW or CCW rotation, motor HP, open or TEFC, voltage and frame size.

Dimensions & Specifications – Metric Units

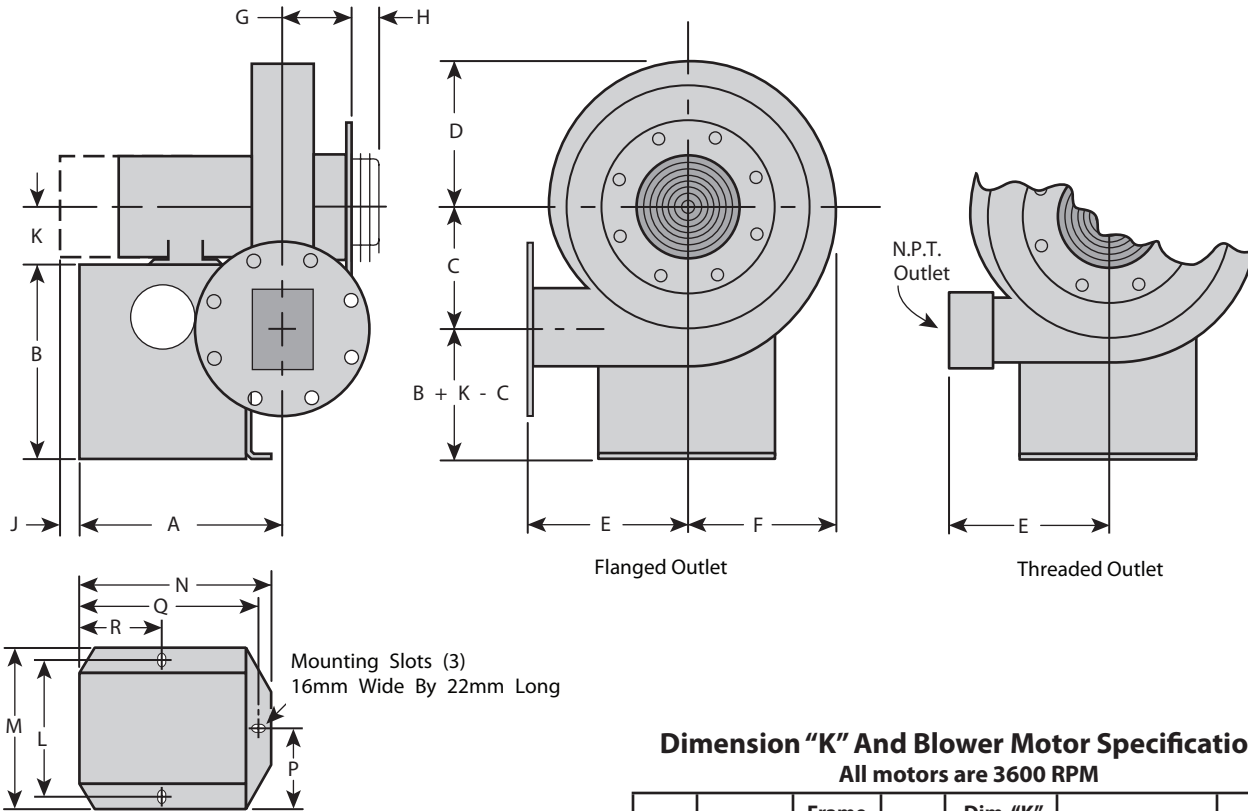

Base*	Dimensions (mm)						Bolt Dia.
	L	M	N	P	Q	R	
1	197	248	254	124	229	98	14
2	235	286	279	143	254	111	14
3	254	305	292	152	279	117	14
4	279	330	305	165	279	124	14
5	305	356	394	178	368	168	14
6	349	400	445	200	419	194	14
7	432	483	495	241	470	219	14

* See the main dimension table to find the base used on each blower.

Flange Dimensions

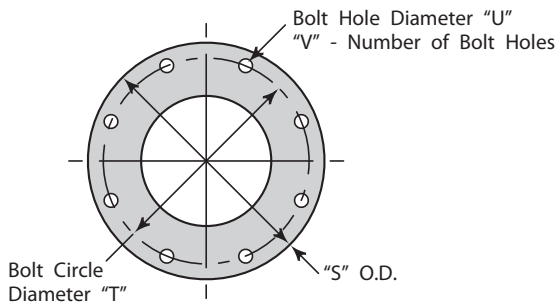

Nominal Pipe Size	Dimensions (mm)				Bolt Dia.
	S	T	U	V	
76	191	152	19	4	16
102	229	191	19	8	16
152	279	241	22	8	19
203	343	298	22	8	19
254	406	362	25	12	22
305	483	432	25	12	22

Flange bolt patterns match ANSI 125# standards.

Dimension "K" And Blower Motor Specifications All motors are 3600 RPM

HP	Encl.	Frame Size	S.F.	Dim. "K" (mm)	V./Ph./Hz.	Part
1/3	Open	48	1.35	76	115/230/1/60	11175
1/3	TEFC	48	1.35	76	115/230/1/60	10755
1/3	Open	48	1.35	76	230/460/3/60	17745
1/3	TEFC	48	1.35	76	230/460/3/60	10448
1/2	Open	48	1.25	76	115/230/1/60	11180
1/2	TEFC	48	1.25	76	115/230/1/60	18776
1/2	Open	48	1.25	76	230/460/3/60	11178
1/2	TEFC	48	1.25	76	230/460/3/60	10449
1/2	Open	56	1.25	89	230/460/3/60	10047
1/2	TEFC	56	1.25	89	230/460/3/60	10032
3/4	Open	56	1.25	89	115/230/1/60	11182
3/4	TEFC	56	1.25	89	115/230/1/60	18777
3/4	Open	56	1.25	89	230/460/3/60	11183
3/4	TEFC	56	1.35	89	230/460/3/60	17723
1	Open	56	1.25	89	115/230/1/60	11187
1	TEFC	56	1.25	89	230/460/3/60	18881
1	Open	56	1.25	89	230/460/3/60	11189
1-1/2	Open	56	1.15	89	115/230/1/60	16742
1-1/2	Open	143T	1.15	89	230/460/3/60	11192
1-1/2	TEFC	143T	1.15	89	230/460/3/60	11197
2	Open	145T	1.15	89	230/460/3/60	11203
2	TEFC	145T	1.15	89	230/460/3/60	11199
3	Open	145T	1.15	89	230/460/3/60	11207
3	TEFC	182T	1.15	114	230/460/3/60	11209
5	Open	182T	1.15	114	230/460/3/60	11213
5	TEFC	184T	1.15	114	230/460/3/60	11210
7-1/2	Open	184T	1.15	114	230/460/3/60	11214
7-1/2	TEFC	213T	1.15	133	230/460/3/60	11215
10	Open	213T	1.15	133	230/460/3/60	11216
10	TEFC	215T	1.15	133	230/460/3/60	11217
15	Open	215T	1.15	133	230/460/3/60	11221
15	TEFC	254T	1.15	159	230/460/3/60	11220
20	Open	254T	1.15	159	230/460/3/60	11224
20	TEFC	256T	1.15	159	230/460/3/60	19894
25	Open	256T	1.15	159	230/460/3/60	14072
25	TEFC	284T	1.15	178	230/460/3/60	16764

Dimensions & Specifications –Metric Units (continued)

Blower Catalog No.	Motor HP ¹	Inlet	Outlet	Dimensions In Millimeters										Base ²
				A	B	C	D	E	F	G	H	J		
SMJ 34123	1/3	102	3" NPT	233	241	191	213	257	221	102	48	—	1	
SMJ 34143	1/2 & 3/4	102	3" NPT	254	241	211	233	268	243	97	48	—	2	
SMJ 3414	1/2 & 3/4	102	76	254	241	211	233	268	243	97	48	—	2	
SMJ 36193	1-1/2 & 2	152	3" NPT	284	318	298	330	397	338	102	48	—	4	
SMJ 44123	1/2	102	4" NPT	244	241	165	200	275	206	113	48	—	1	
SMJ 44123	3/4	102	4" NPT	270	241	165	200	275	206	113	48	—	1	
SMJ 46103	1/3 & 1/2	152	4" NPT	249	241	148	170	249	175	117	48	32	1	
SMJ 46143	1	152	4" NPT	292	318	221	254	351	259	110	48	—	4	
SMJ 46153	3/4 & 1	152	4" NPT	292	318	221	254	351	259	110	48	—	4	
SMJ 46163	1 & 1-1/2	152	4" NPT	289	318	241	283	376	303	106	48	—	4	
SMJ 46173	1-1/2	152	4" NPT	289	318	241	283	376	303	106	48	—	4	
SMJ 46193	2	152	4" NPT	286	318	298	330	402	338	102	48	—	4	
SMJ 4621	2	152	102	386	394	324	365	429	368	114	48	—	5	
SMJ 4623	3	152	102	389	394	344	373	391	391	117	48	—	5	
SMJ 4623	5	152	102	389	394	356	383	391	391	117	48	—	5	
SMJ 4628	5 & 7-1/2	152	102	433	483	429	462	467	470	116	48	—	6	
SMJ 6614	1-1/2 & 2	152	152	316	318	210	249	314	254	133	48	—	4	
SMJ 6615	2	152	152	316	318	210	249	314	254	133	48	—	4	
SMJ 6617	2 & 3D	152	152	302	318	238	283	340	286	121	48	13	4	
SMJ 6617	3E	152	152	302	318	238	283	340	286	121	48	—	4	
SMJ 6619	3	152	152	386	394	298	330	365	338	114	48	—	4	
SMJ 6619	5	152	152	386	394	298	330	365	338	146	48	—	5	
SMJ 6621	3 & 5	152	152	375	394	305	357	365	370	103	48	—	5	
SMJ 6623	7-1/2	152	152	405	394	319	381	441	387	132	48	—	5	
SMJ 6812	1,1-1/2,2D	203	152	305	318	186	214	264	224	133	48	—	3	
SMJ 6812	2E	203	152	305	318	186	214	264	224	133	48	13	3	
SMJ 8813	3D	203	203	368	318	225	254	314	268	186	48	—	4	
SMJ 8813	3E	203	203	368	318	225	254	314	268	186	48	14	4	
SMJ 8814	3	203	203	406	394	246	286	314	306	133	48	—	5	
SMJ 8815	3 & 5	203	203	406	394	246	286	314	306	133	48	—	5	
SMJ 8816	5	203	203	406	394	246	286	314	306	133	48	—	5	
SMJ 8817	5 & 7-1/2	203	203	418	394	251	279	352	302	146	48	—	5	
SMJ 8819	7-1/2 & 10	203	203	410	394	330	364	391	386	138	48	—	5	
SMJ 8821	7-1/2 & 10	203	203	470	483	356	394	391	418	133	48	—	6	
SMJ 8823	10 & 15	203	203	511	483	370	406	416	429	140	48	—	7	
SMJ 8828	10 & 15D	203	203	495	483	387	460	568	467	124	48	—	7	
SMJ 8828	15E,20,25D	203	203	495	483	387	460	568	467	124	48	40	7	
SMJ 8828	25E	203	203	495	483	387	460	568	467	124	48	79	7	
SMJ 101016	7-1/2	254	254	475	394	275	305	365	324	203	60	—	5	
SMJ 101016	10	254	254	525	483	275	305	365	324	203	60	—	6	
SMJ 101018	15D	254	254	514	483	311	337	365	370	192	60	—	6	
SMJ 101018	15E	254	254	514	483	311	337	365	370	192	60	48	6	
SMJ 101019	10	254	254	502	483	330	365	391	387	179	60	—	6	
SMJ 101021	15 & 20	254	254	545	483	356	394	391	418	171	60	—	7	
SMJ 101023	20	254	254	529	483	376	406	467	432	157	60	—	7	
SMJ 101023	25D	254	254	529	483	376	406	467	432	157	60	41	7	
SMJ 101023	25E	254	254	529	483	376	406	467	432	157	60	79	7	
SMJ 121217	10 & 15D	305	305	525	483	275	305	365	324	203	60	—	6	
SMJ 121217	15E	305	305	525	483	275	305	365	324	203	60	44	6	
SMJ 121219	15D	305	305	584	483	330	368	391	387	210	60	—	7	
SMJ 121219	15E	305	305	584	483	330	368	391	387	210	60	—	7	
SMJ 121220	20	305	305	584	483	330	368	391	387	210	60	—	7	
SMJ 121221	25D	305	305	560	483	356	395	391	418	187	60	41	7	
SMJ 121221	25E	305	305	560	483	356	395	391	418	187	60	79	7	
SMJ 121222	25D	305	305	560	483	356	395	391	418	187	60	41	7	
SMJ 121222	25E	305	305	560	483	356	395	391	418	187	60	79	7	

¹D=open motor; E=enclosed motor. Horsepowers with no letter suffix are either open or enclosed.

²Refer to the base chart on page 4 for base mounting dimensions.

³ Signifies an N.P.T. threaded outlet. All other blowers have flanged outlets with standard ANSI 125# bolt patterns. All inlets are flanged. Companion flanges are not standard, but are available at a nominal cost.

To Order: Specify blower catalog number, CW or CCW rotation, motor HP, open or TEFC, voltage and frame size.



Offered By:

Power Equipment Company
2011 Williamsburg Road
Richmond, Virginia 23231
Phone (804) 236-3800
Fax (804) 236-3882

www.peconet.com